

Water Control Equipment

Series 300

Contents

Introduction	2
Advantages	2
Model 310 Telescoping Valve	3-4
Model 340 Butterfly Gate	5-7

Introduction

Series 300 gates are comprised of specialized water control equipment tailored for specific applications. Whipps, Inc. can economically produce customized water control equipment for both standard and non-standard applications. Our company offers telescoping valves and butterfly gates with high performance and longevity, designed with rugged, reinforced construction combined with a heavy-duty, low-leakage seal. Our butterfly gates are sealed on all sides with UHMW/rubber seals, rotating around a thrust bearing 90 degrees to open and close with less effort required for slide gates the same size. The water control equipment manufactured by Whipps, Inc. is constructed of corrosion-resistant materials such as type 304/304L or type 316/316L stainless steel.

Advantages

Performance: Utilizing compressible seals provides superior leakage performance compared to traditional cast iron water control equipment with bronze seating faces.

Design Flexibility: All series 300 gates are custom-built for each application, allowing various mounting arrangements and a nearly unlimited range of sizes.

Corrosion Resistance: Painting or recoating stainless steel is not required to resist corrosion in water and wastewater.

Field Replaceable Seals: If the seals were ever to become damaged, they are easily removable and replaceable. In contrast, the bronze seating faces on traditional cast iron water control equipment cannot be replaced in the field.

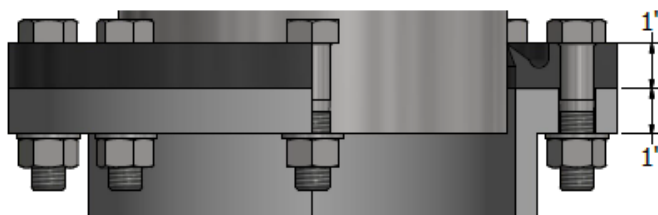

Model 310 Telescoping Valve

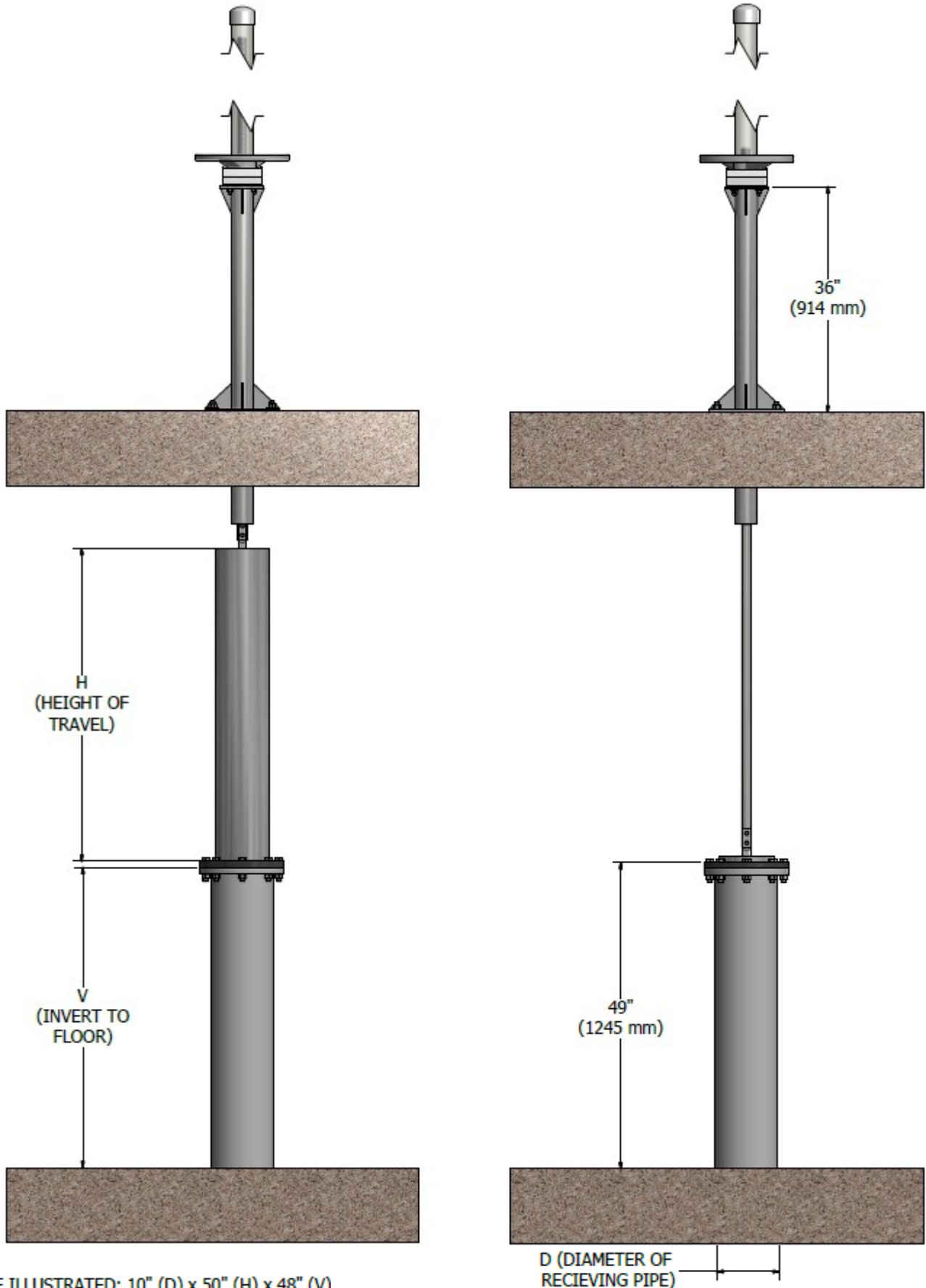

GATE ILLUSTRATED: 10" (D) x 50" (H) x 48" (V)

Model 310 Features

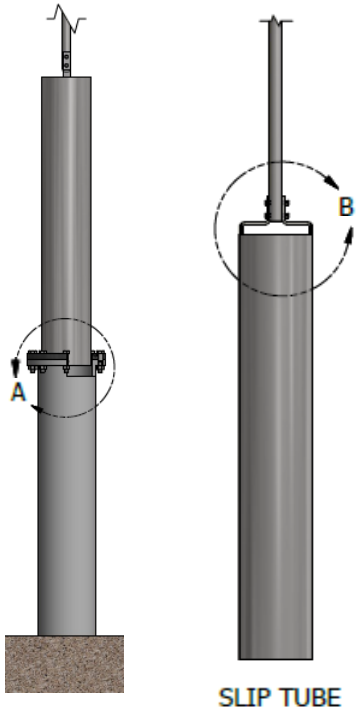

Model 310 telescoping valves are typically designed with diameters between 4 and 18 inches. They feature slip tube construction in stainless steel, brass, or PVC with plain or v-notched tops. Operation is facilitated by a gear box that drives a threaded stem, which can either be rising or non-rising. Rack and pinion operators are an alternative option available upon consultation.

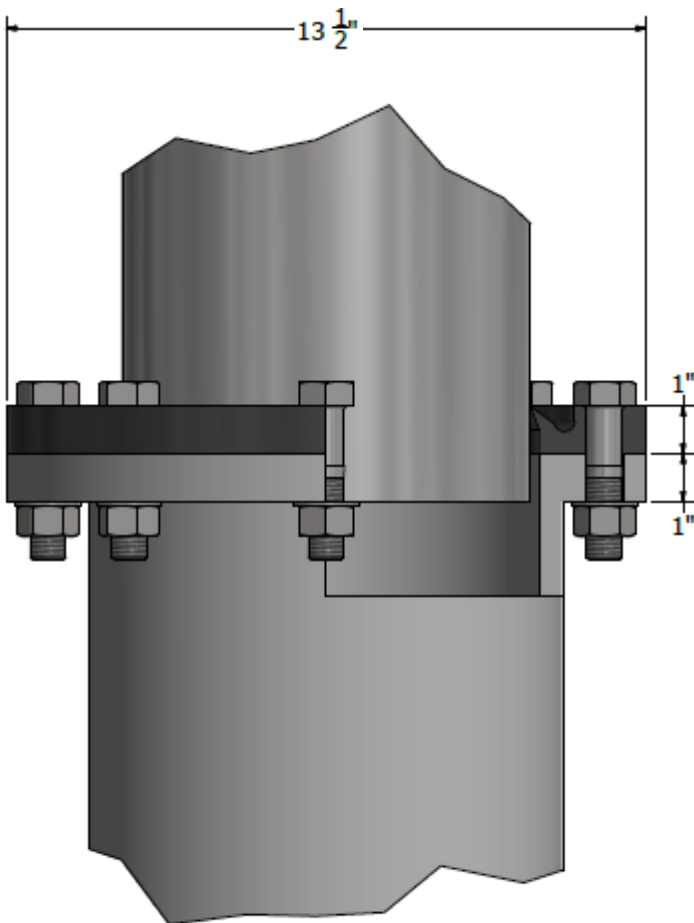

DETAIL A
FLANGE & SEAL

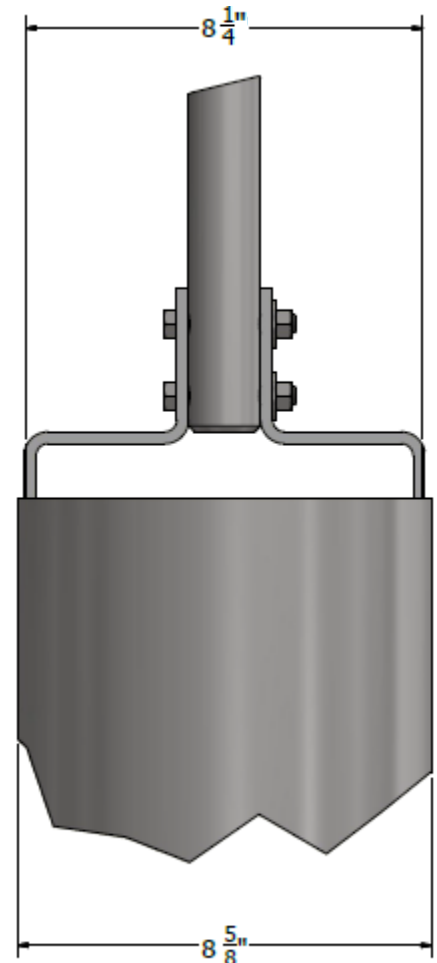

DETAIL B
VALVE BAIL

Model 340 Butterfly Gate

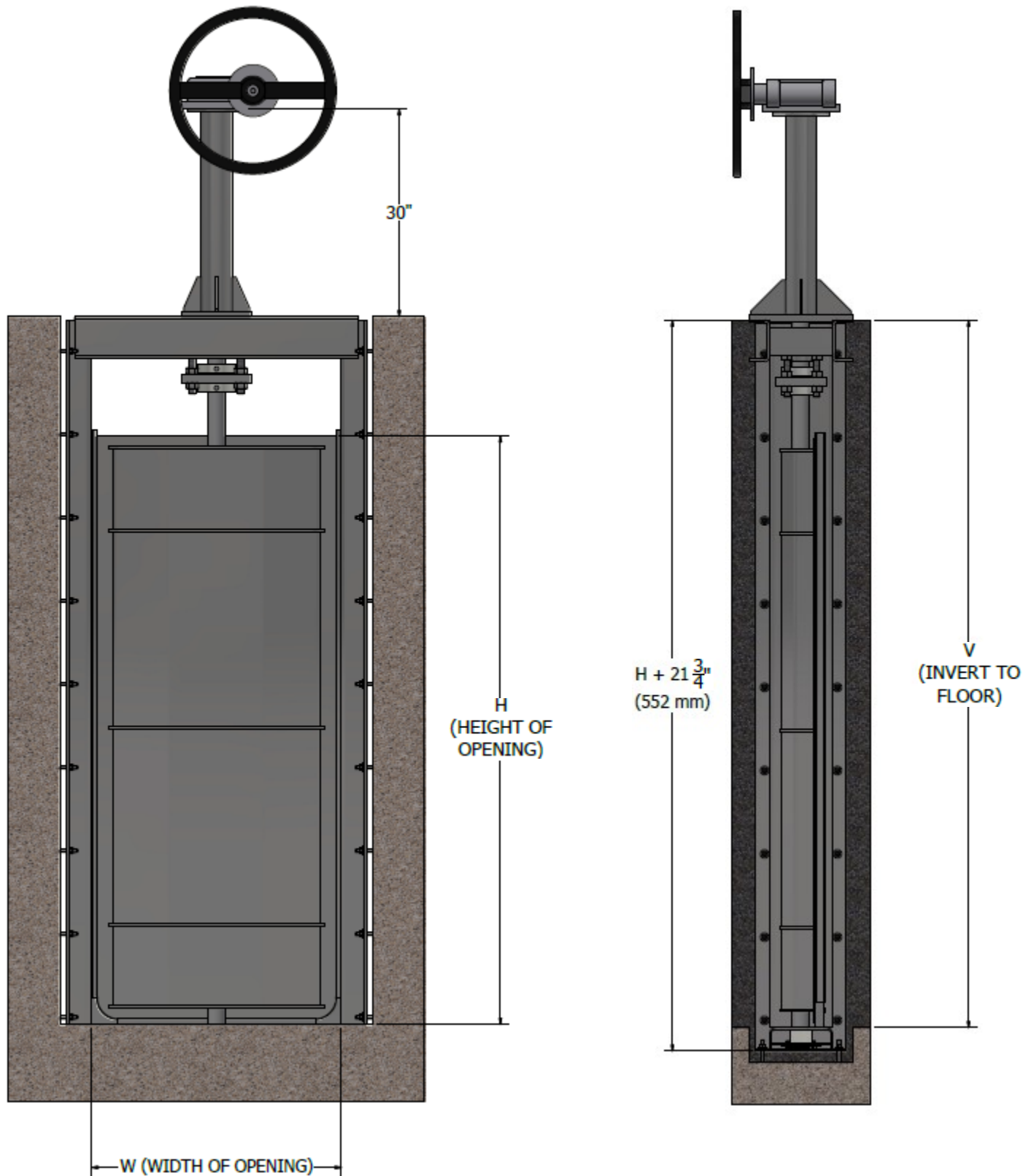

GATE ILLUSTRATED: 36" (W) x 84" (H) x 102" (V)

Model 340 Features

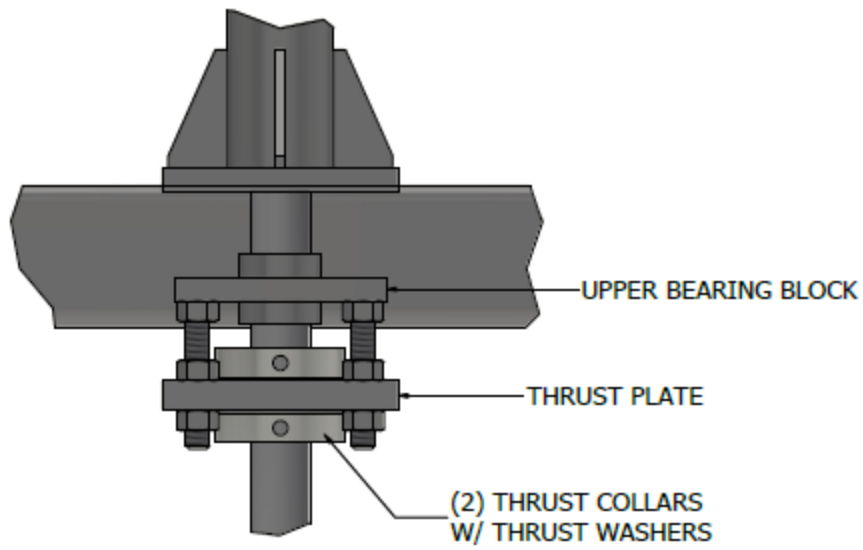

DETAIL A
UPPER THRUST BEARING

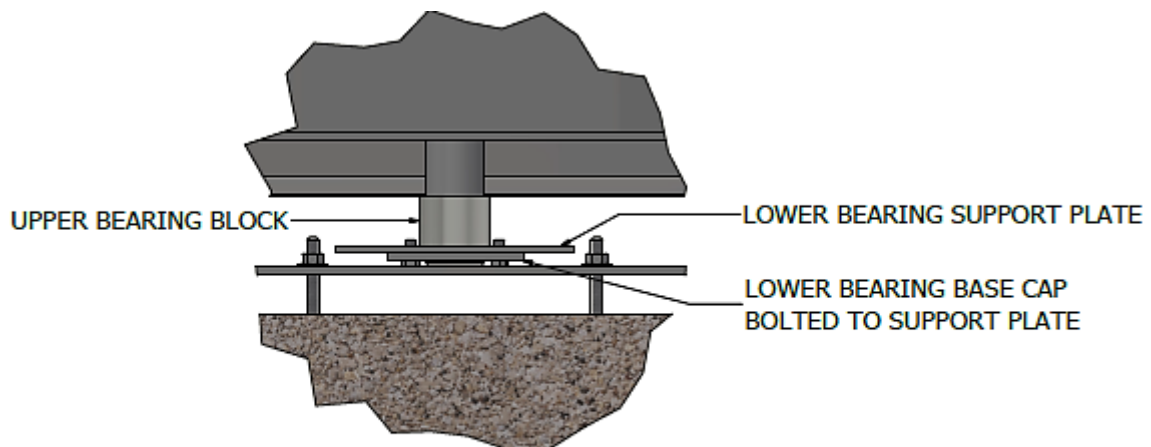
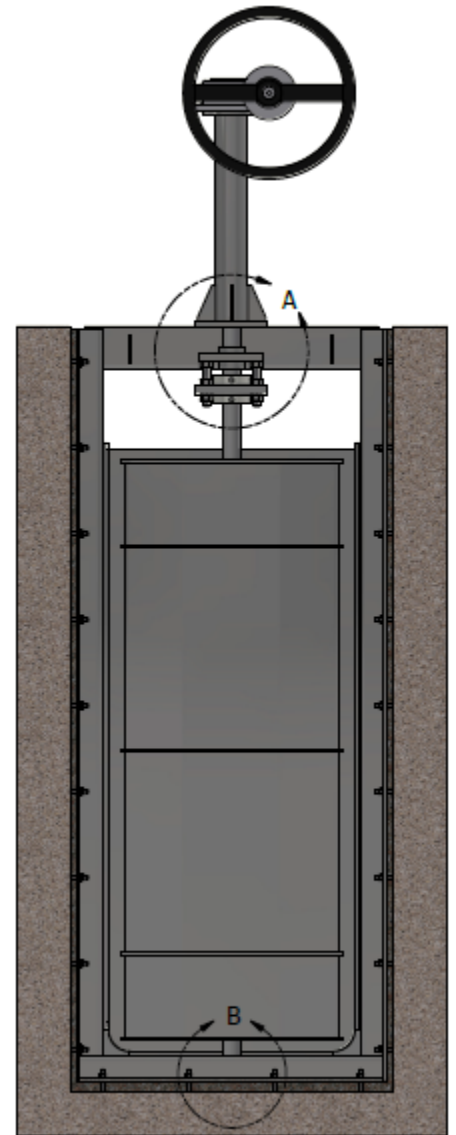

DETAIL B
LOWER BEARING

Model 340 Butterfly Gate Door

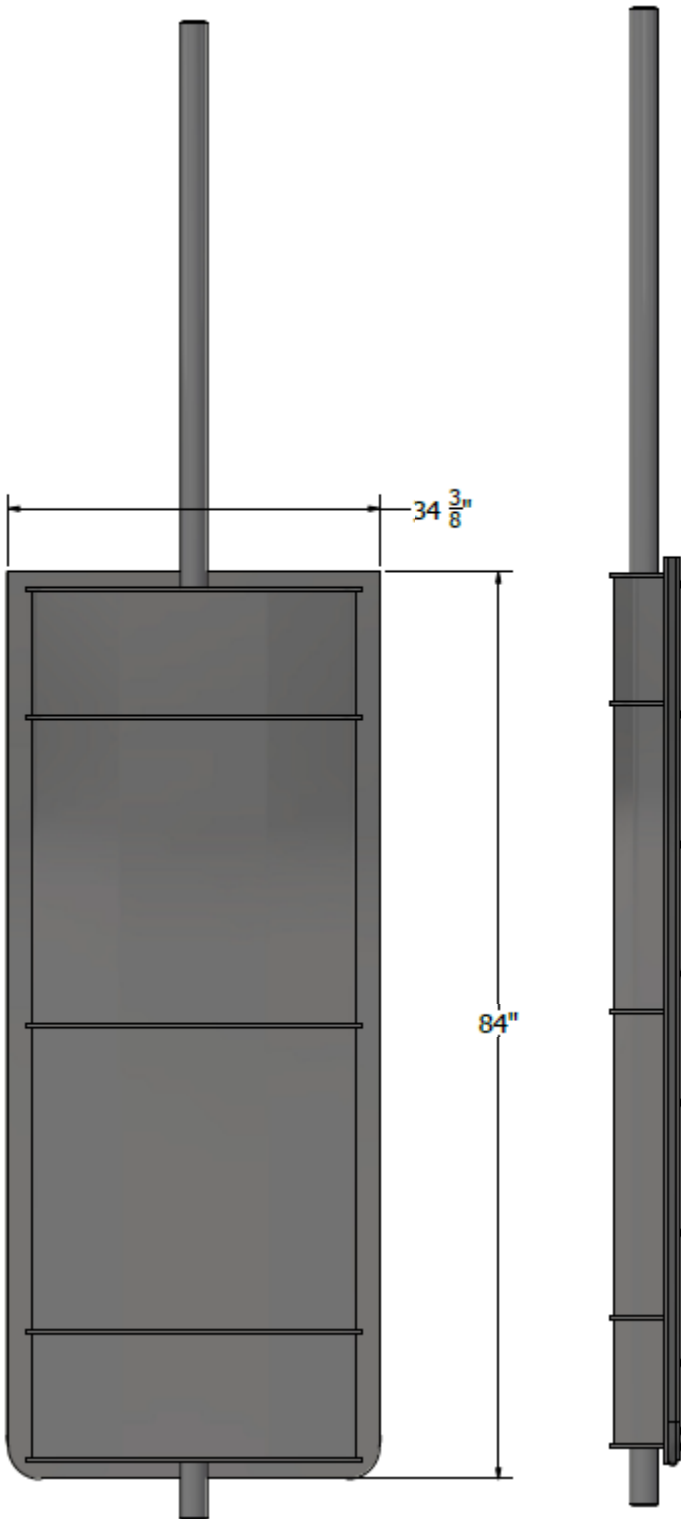

BUTTERFLY GATE TOP VIEW



BUTTERFLY GATE OPEN

